

索引号 04124 ①
INDEX NO.

图纸修改			REVISIONS	
日期	版次	更改标记	更改简述	更改单号
DATE	ISSUE	CHANGED INDEX NO.	DESCRIPTION	CHANGE NO.
06.12.11	D	①	更改索引号	G06-135
07.4.11	E	②	材料由304更改为301	G07-084
07.8.28	F	③	增加热处理要求	G07-277

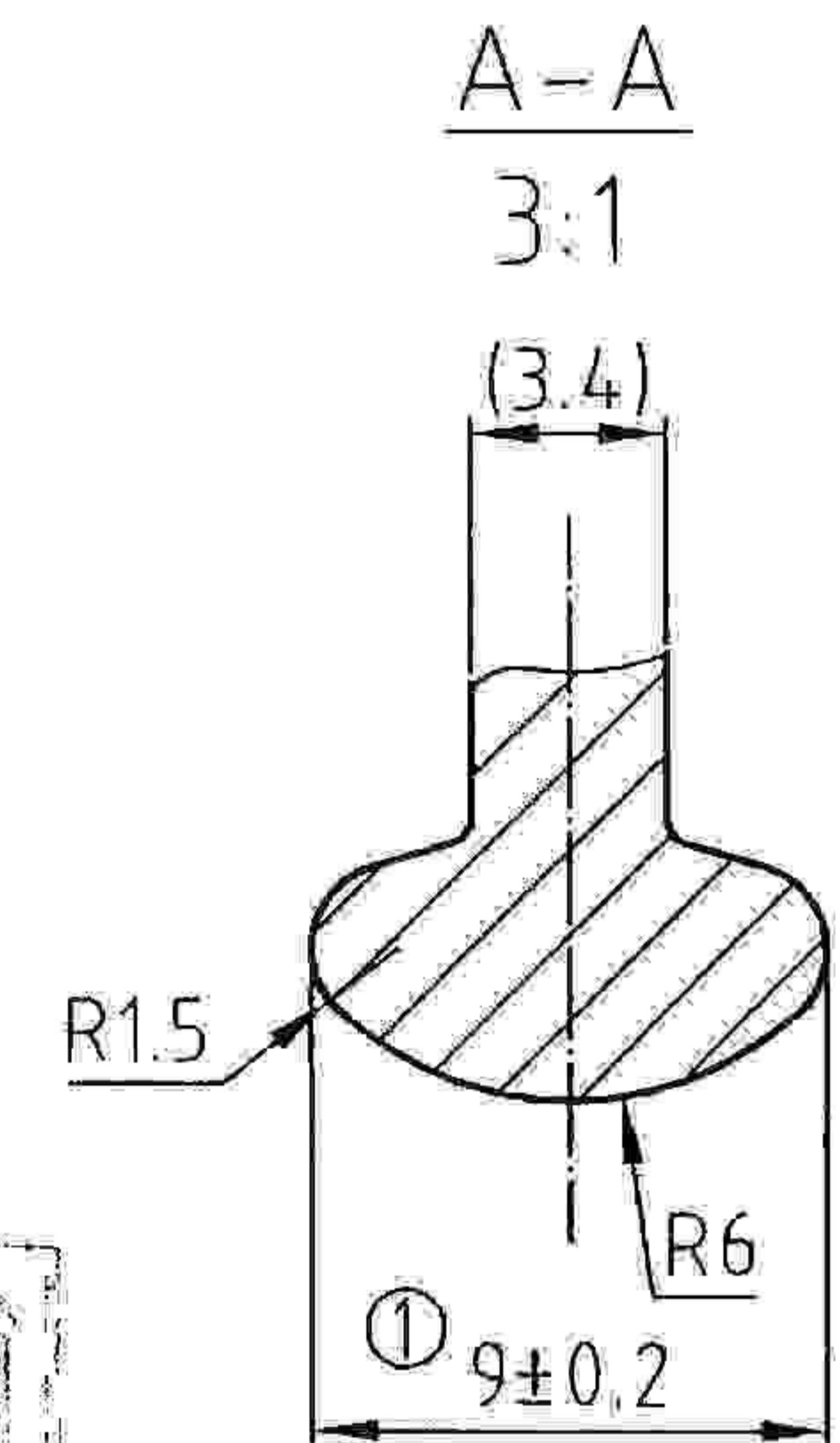
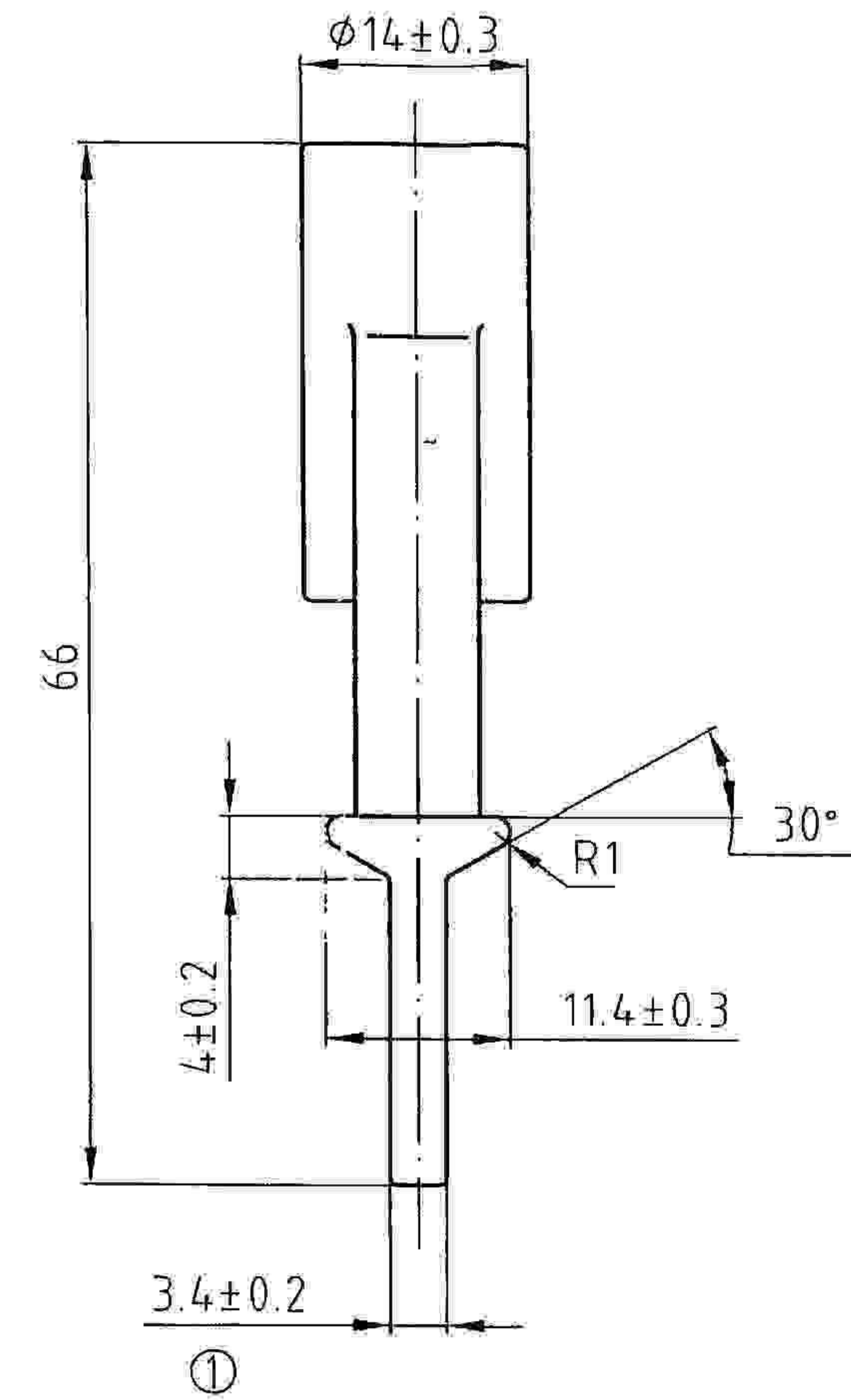
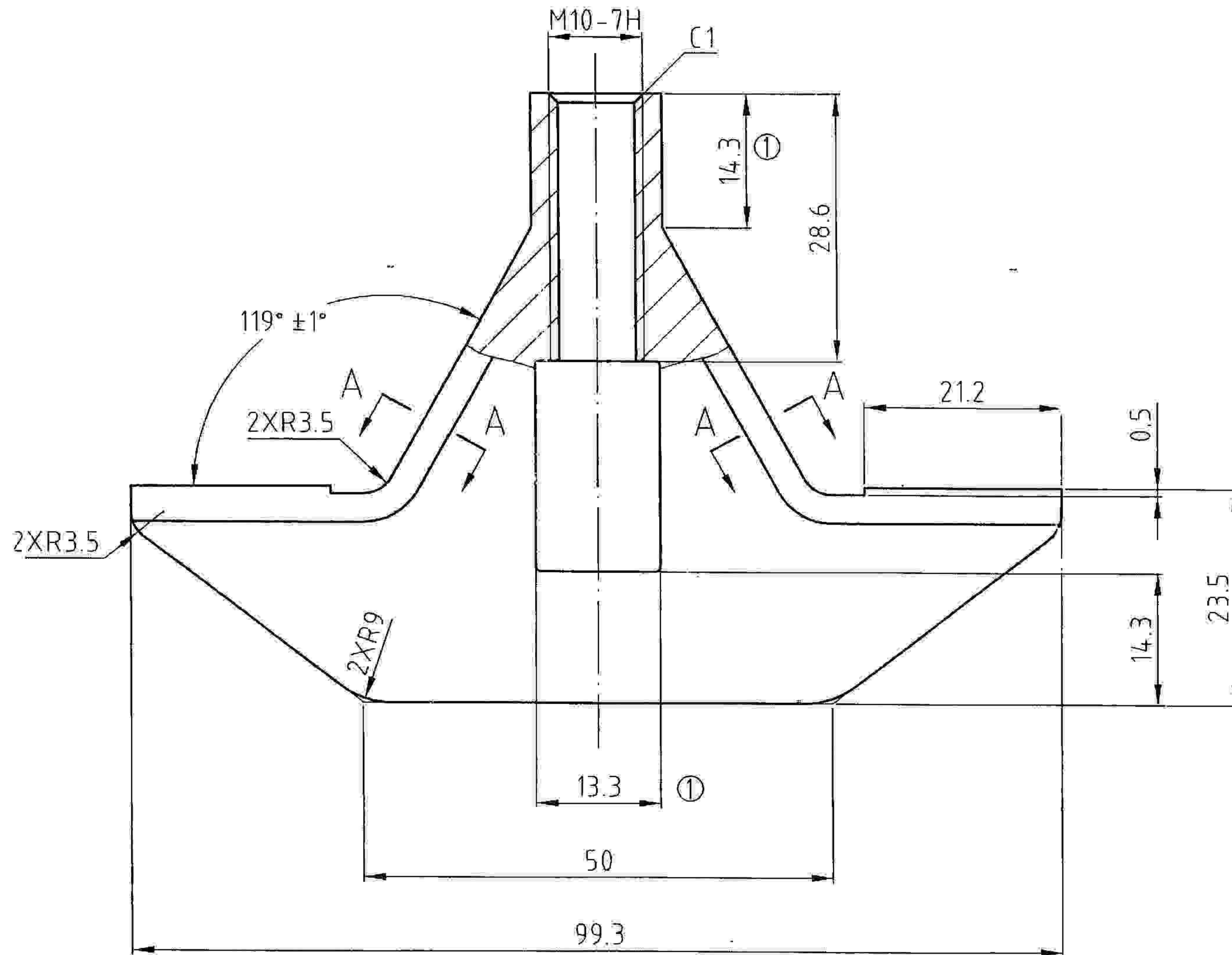

3.2/

试制确认
TRIAL-PRODUCE
生产确认
PRODUCE AFFIRM
工艺
TECH

技术要求

- 1 未注尺寸偏差按±0.5;
- 2 未注铸造圆角为R0.5;
- 3 零件不得有气孔、裂纹和缺块等铸造缺陷;
- 4 表面酸洗后喷丸处理;
- ③ 5 产品进行固溶处理

NOTES

- 1 UNSPECIFIED TOLERANCE TO BE ±0.5;
- 2 UNSPECIFIED CAST FILLET TO BE R0.5;
- 3 PART TO BE FREE FROM AIR HOLES, CRACK ETC.
- 4 SURFACE TO BE PILL SPRAY AFTER ACID CLEANING;
- ③ 5 PART TO BE HOMOGENIZATION PROCESSED BY HEAT TREATMENT

设计 DESIGN	平兴朝	材料 MATERIAL	301 ②	ZITIC
校对 CHD				
审核 AUDIT		比例 SCALE	1.5:1	PART NO. 1196-15
批准 APPROVAL		页数 SHEET	1 OF	
		客户版本 CUSTOMER ISSUE	NO	